

A few simple steps to ensure
perfect water, every time.



We're Here to Help



We are also available
for live video chat!

Email Us:

support@avalonh2o.com
sales@avalonh2o.com

Availability:

Monday-Friday: 9 a.m.-5 p.m.

Let's Connect

Follow our social media accounts and stay up to
date on the latest Avalon news.



@avalon_h2o



Avalon Water Coolers



Avalonh2o

www.avalonh2o.com

Use and Care Guide

MODEL: A50-SB

Registration

Please visit the website below to register your new water cooler within the first 30 days of purchase. Registration within the first 30 days will activate your one year warranty.

www.avalonh2o.com/register-my-avalon-cooler

Please keep your model number, order number and purchase date for future support. You can reach us at support@avalonh2o.com.

Model Number _____

Order Number _____

Purchase Date _____

Contents

About Your Product

Meet Your Avalon Product	6-7
Caution & Notices Before Installation	8
Part Names	9
Tech Specs	10
Electric Principle Diagram	11
Models & Functions	12
Introduction of Display Board	12
Explosion Diagram	13

Getting Started

Installation Template	15
Installation	16-21
Flushing the Filters	22
Dispensing Water	23
Filter Replacement	24-26
Connecting to the App	27

Troubleshooting

Warranty

28
30

Meet Your Avalon Product

Inside the box, you'll find:

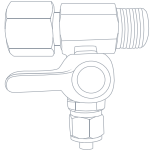

Metal Adapter with Valve
(3/8" compression)

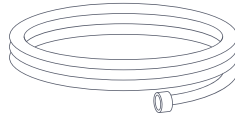

Drain Tube
(10')

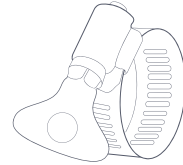

Drain Tube Clamp

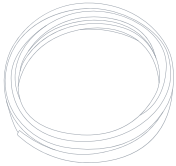

3/8" Tubing
(10')

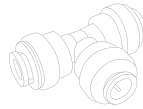

**Three Way
Plastic Adapter**
(3/8")

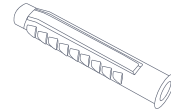

Drywall Anchors
(x6)

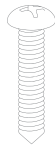

40mm Screws
(x6)



Wrench

Meet Your Avalon Product



Attractive Design

Elegant design with brushed stainless steel surface



Crisp, Cold Water (with optional A50-CC chiller)

Applicable for any environment where there is a demand for a chilled water source



Easy Bottle Filling

Suitable for bottle or cup filling



Touchless Sensor

Hand-activated infrared sensor for water cooling & bottling



Leak Detection Sensor

Built-in leakage detector, safe & user-friendly



Status Indicator Light

Visual filter status indicator & reminder of filter replacement if necessary



Dual Filtration

Inbuilt water filter to reduce lead, large particles, chlorine, taste and odor in water



High Cooling Efficiency (with optional A50-CC chiller)

Hermetically compressor, copper-tube winding cooling tank with high cooling efficiency



Environmentally Friendly

Green Tips inform user of number of plastic water bottles saved



UV Sterilization

UV sterilizing lamp to prevent bacteria

Caution & Notices Before Installation

1. The power supply of this machine is 110V/60Hz AC with effective grounding.
2. After the cooler is secured, connect the drainage, water inlet and power supply.
Touch sensing area with hand to fill water. Move away your hand after water flows out from faucet.
3. Replace the filters in accordance with the filter indicator.
4. Contact manufacturer or local agent to replace the filter and spare parts.
5. Set the device at a location with good ventilation; ensure air circulation at both sides.
Keep the device clean.
6. This water cooler is not recommended or designed for outdoor applications or closed areas, and failure to heed these conditions may void warranty.

*If there is something wrong with the device, please contact the manufacturer or local agent. Manufacturer is not responsible for any damage caused by self-disassembling.

Part Names

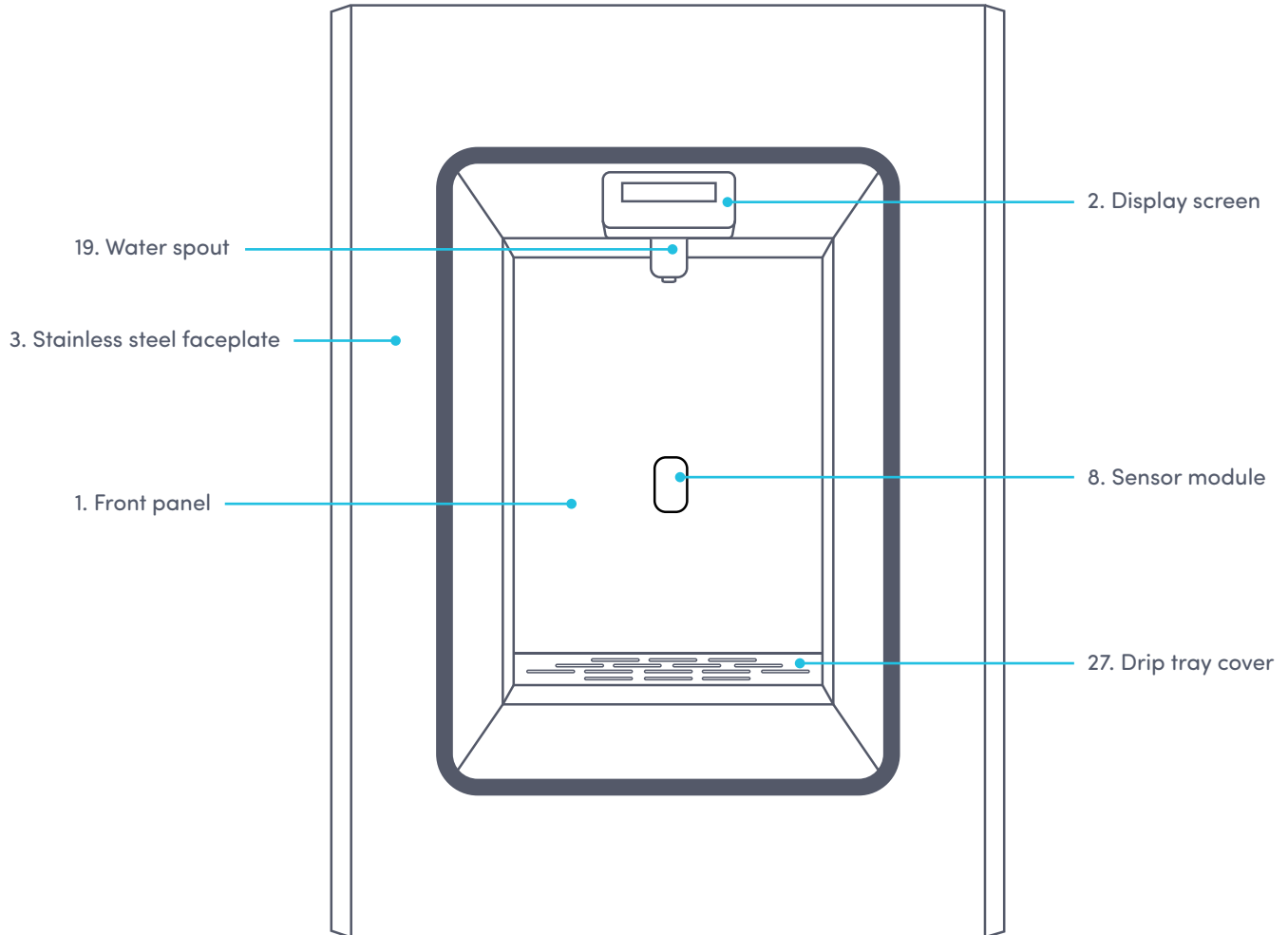

Tech Specs

Rated Voltage/Rated Frequency	AC 110V / 60Hz
Refrigerant	R134a/110g
Rated Cooling Power	200W
Rated Cooling Current	2.5A
Cold Water (when used together with model A50-CC)	46.4°F- 53.6°F 20L/h
Ambient Temperature	50°F- 100.4°F
Protection Type For Electric Shock	Class I
Water Source	0.07-0.5MPa City water

Electric Principle Diagram

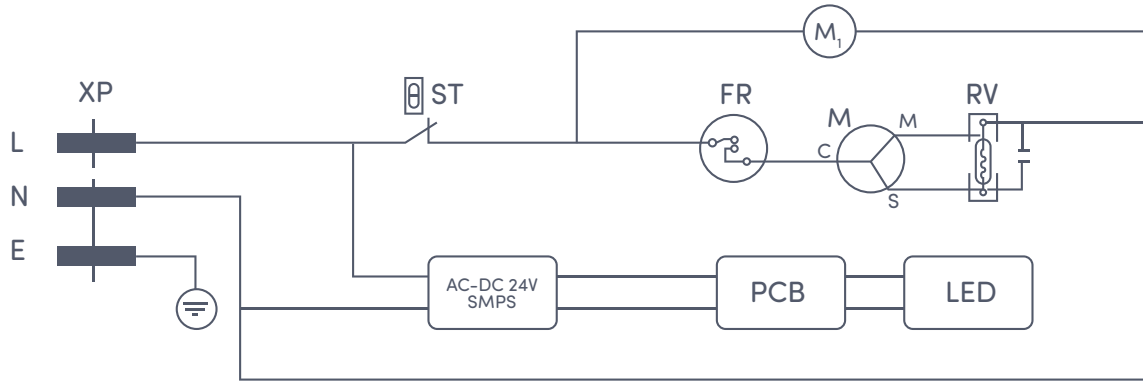

XP:inlets ST:thermostat RV:starter M:compressor
FR:overload protector M1:fan

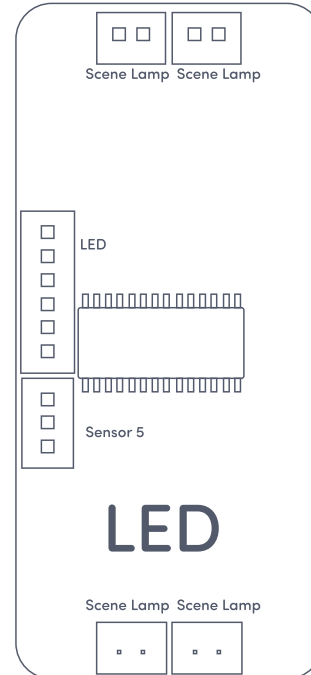
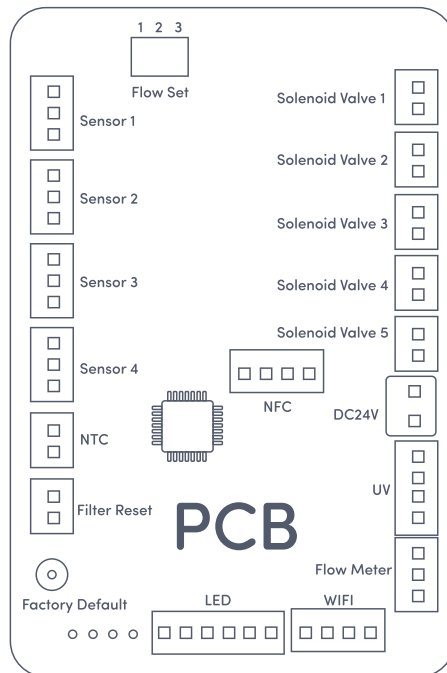

Models And Functions

Model	Bottle Filler
A50-SB	1

Display Board

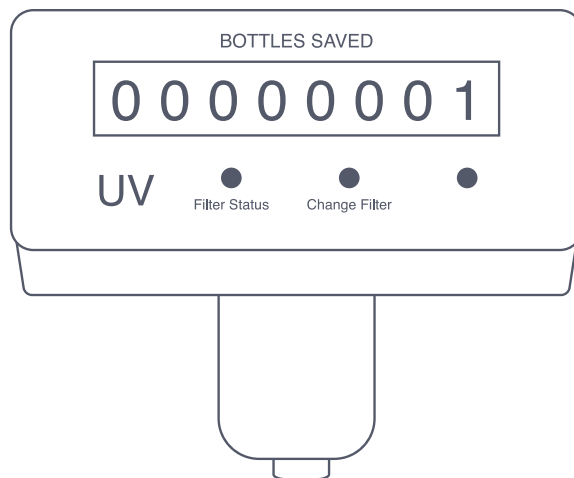

Explosion Diagram

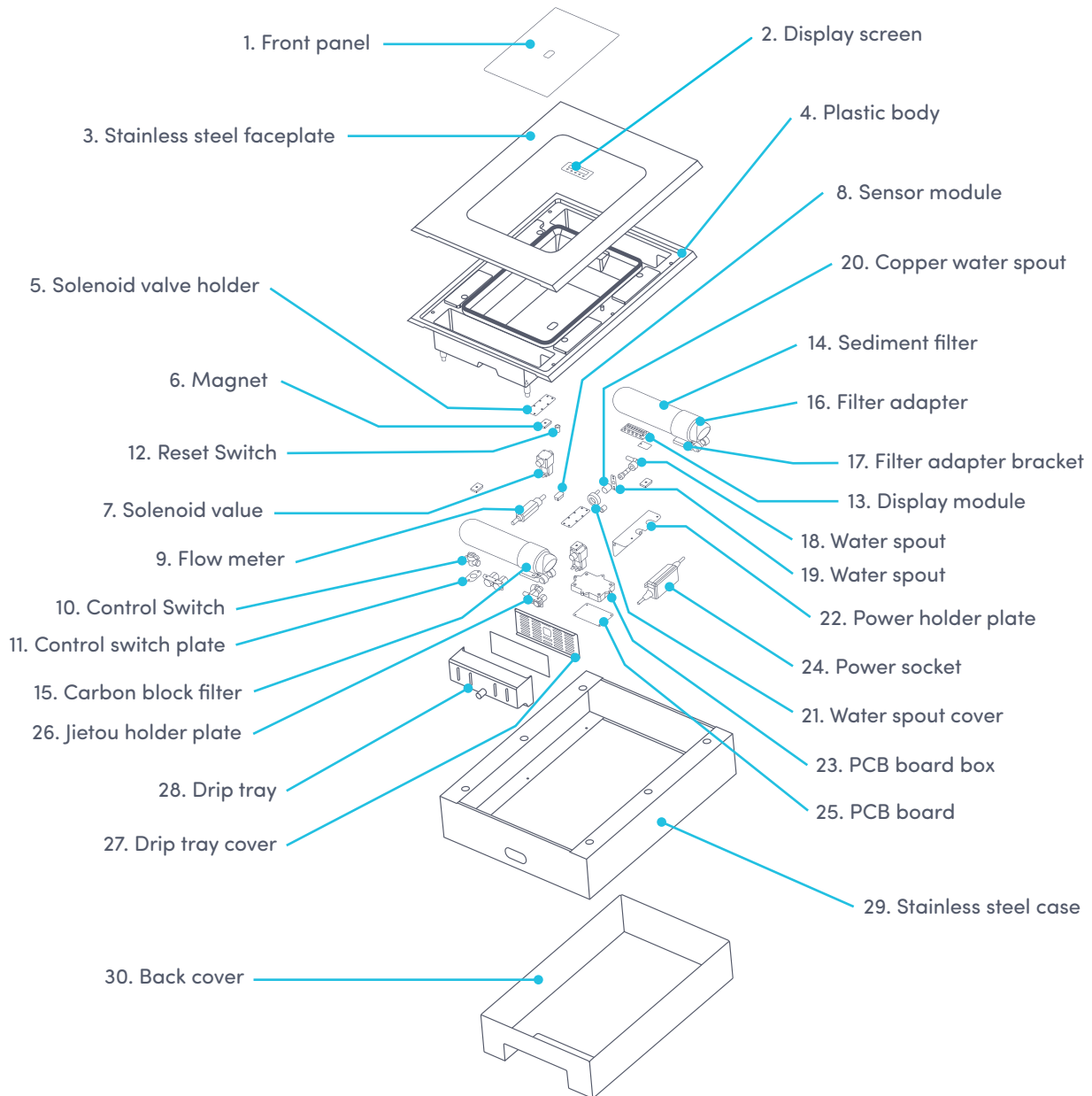

Installation

Installation Template

Screw holes

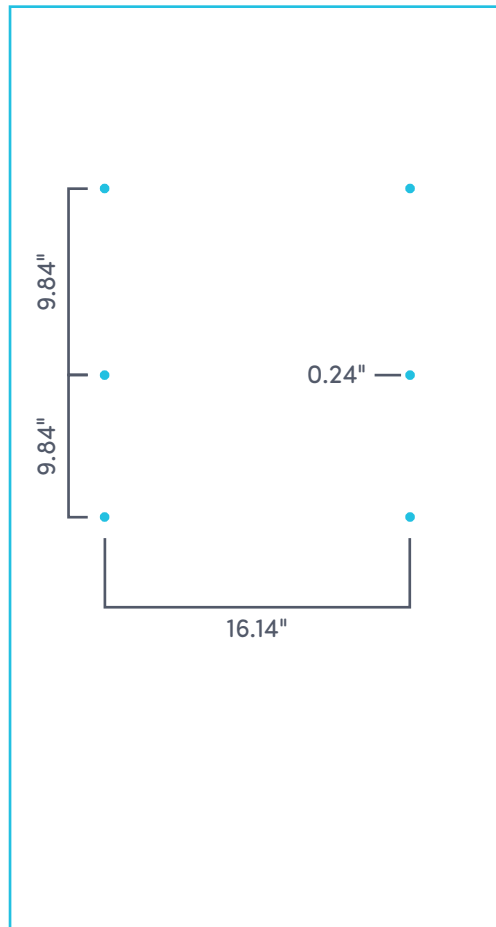

Installation

1. Remove the 2 screws on the underside of the unit.

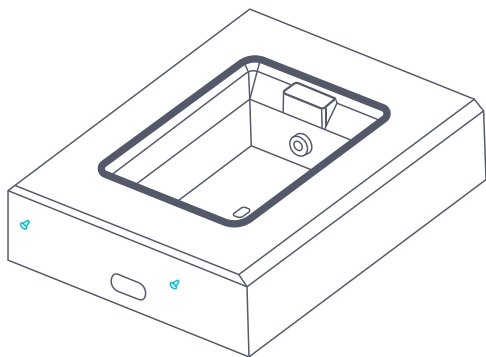

2. Remove the stainless steel faceplate by lifting it off.

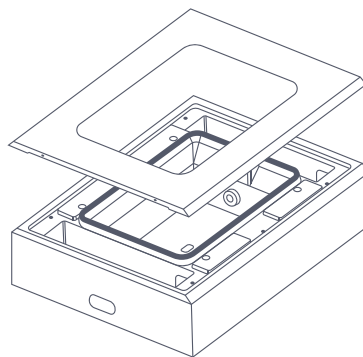

3. Remove the 6 screws from the plastic body.

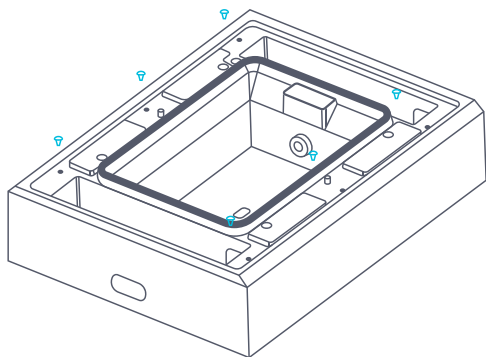

4. Lift the plastic body out of the stainless steel case.

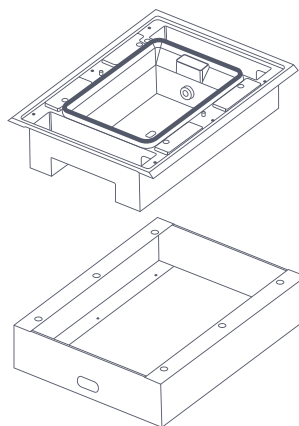

Installation

5. Mount the stainless steel case to the wall using the included 6 expansion screws.

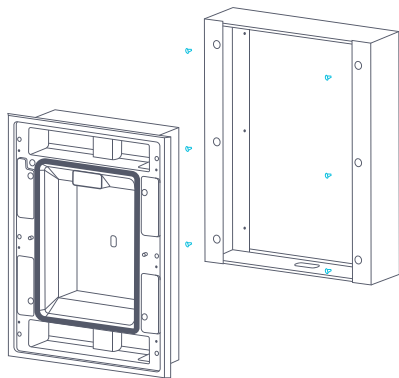

7. Connect the included drain tubing to the right side connection on the lower back of the unit. Place the included metal hose clamp around this end and tighten it. Connect the other end of this tubing to your drain line inside or near the wall.

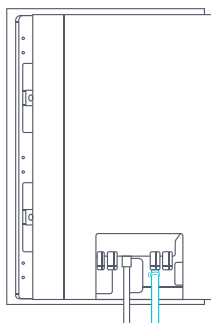

6. Connect the included 3/8" tubing into the left inlet connection on the lower back of the unit. Connect the other end of this tubing to your water line inside or near the wall.

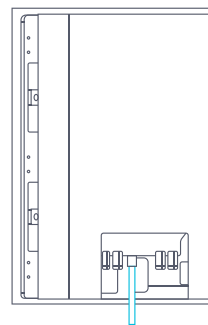

8. If you are installing this together with model A50-CC cooling system, place the cooling system in a location nearby the wall bottle filler. This can be placed on a shelf, under a cabinet, or in the wall below the bottle filler with the Avalon A50-GRILL covering it.

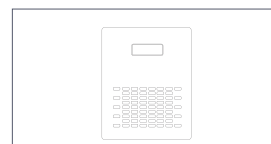
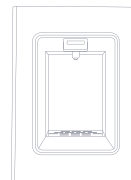

Installation

9. Locate the tubing that is between the water inlet and water outlet on the lower back of the Avalon Wall Bottle Filler.

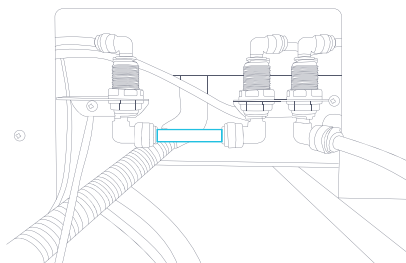

10. Disconnect this tubing by removing the 2 blue locking clips and pressing on the push connect fittings.

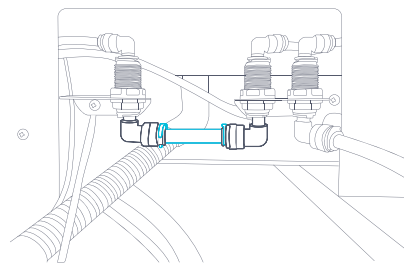

11. Connect one end of the included non insulated 3/8" tubing to the left push connect fitting (when facing the back of the unit) next to the power cord that was just opened in the previous step. You may do so by feeding it behind the unit or through the hole in the case below the unit depending on your installation method and location.

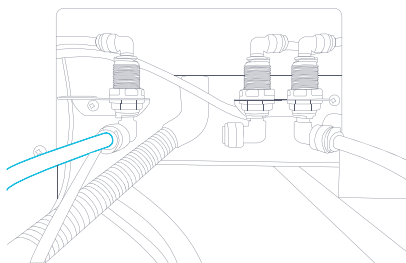

12. Connect the other end of the 3/8" non insulated tubing to the water inlet of the cooling system.

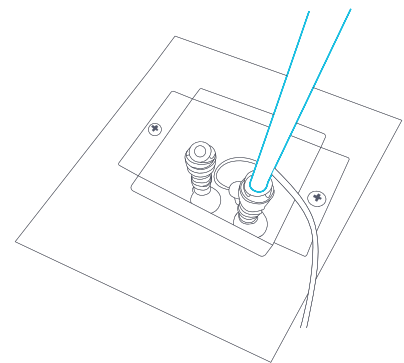

Installation

13. Connect one end of the included insulated 3/8" tubing to the right push connect fitting next to the water line running to the Avalon Wall Bottle Filler that was just opened in the step 4. You may do so by feeding it behind the unit or through the hole in the case below the unit depending on your installation method and location.

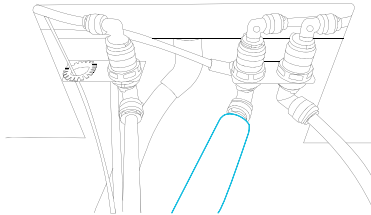

15. Unravel the wiring leading from inside the cooling system and connect it to the connection end of the black wiring leading from the PCB on the Avalon Wall Bottle Filler PCB board of the Avalon Wall Bottle Filler.

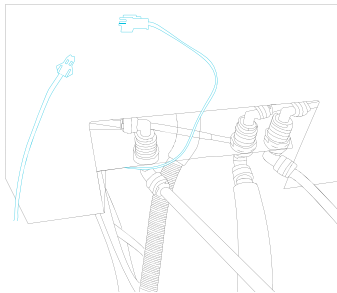

14. Connect the other end of the insulated 3/8" tubing to the outlet of the cooling system.

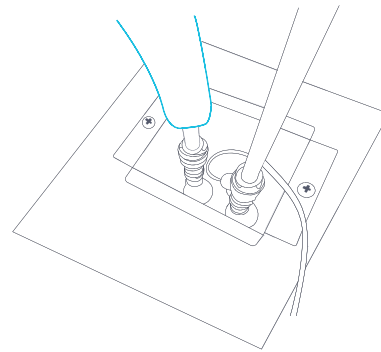

16. Plug one end of the power cord to the back of the cooling system.

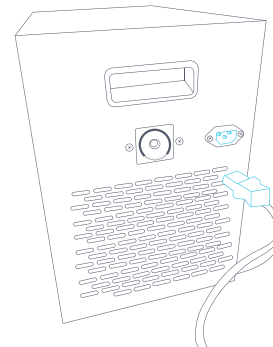

Installation

17. Plug the other prong end of the power cord into a grounded power outlet.

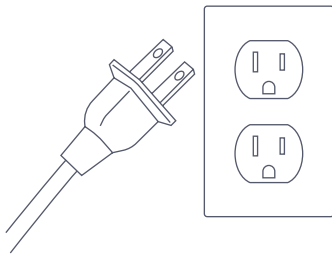

18. Plug in the power cord to a power source. You may also feed this through the hole located at the bottom of the stainless steel case if needed.

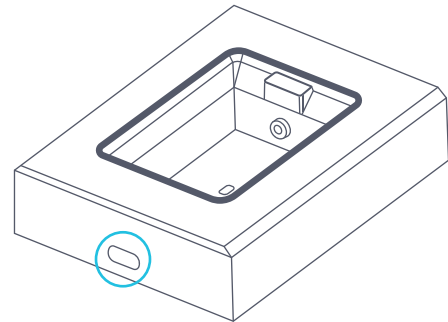

19. Insert the plastic body back into the stainless steel case and screw the 6 screws back into place to secure it.

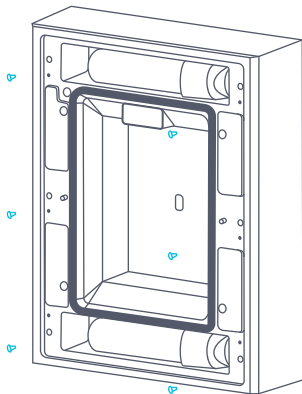

20. Install the stainless steel faceplate onto the front of the unit by lowering it onto the 2 notches at the top.

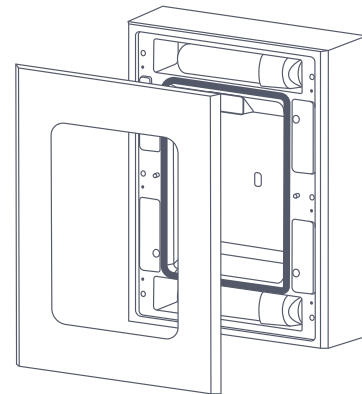

Installation

21. Screw on the 2 screws on the underside of the unit to secure the stainless steel faceplate.

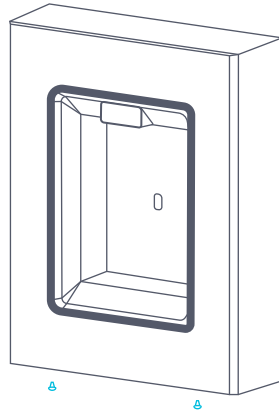

Flushing the Filters

1. Upon finishing installation, place your hand in front of the infrared sensor on the dispense area to activate the dispense of water from the spout. Do this for 1 minute to properly flush the new filters. The bottle filler will stop dispensing water after 30 seconds for safety purposes so you may need to replace your hand in front of the sensor more than 1 time.

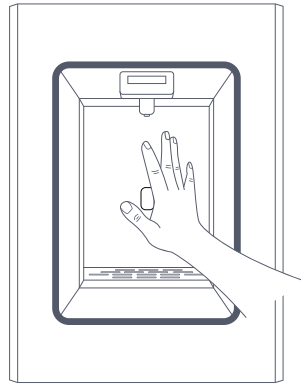

Dispensing Water

1. Place your water bottle or drinking cup in the dispense area in front of the sensor to dispense water. The infrared sensor will activate the flow of water from the water spout.

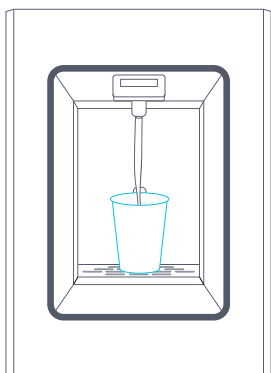

2. The digital display will keep track of "Bottles Saved" each time you dispense water.

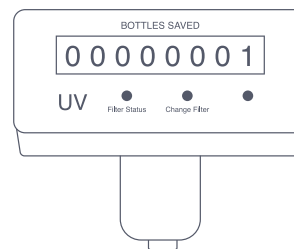

3. The UV self cleaning feature will also be activated each time you dispense water ensuring there is no bacteria in your water.

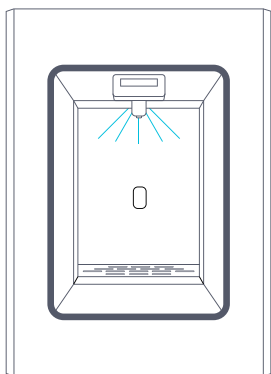

4. Once the desired level of water in your bottle or cup is reached, remove the bottle or cup from in front of the infrared sensor and the water will stop dispensing.

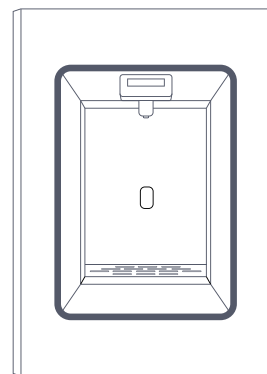

Filter Replacement

1. Remove the 2 screws on the underside of the unit.

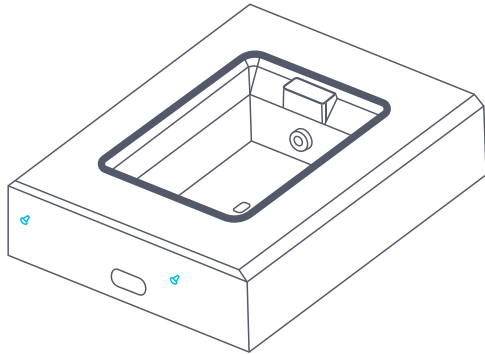

2. Remove the stainless steel faceplate by lifting it off.

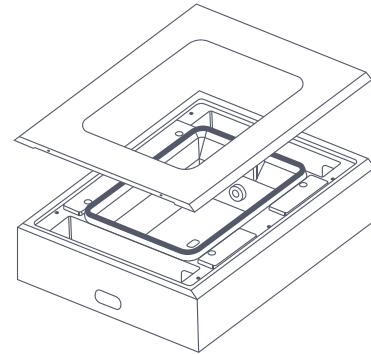

3. Turn off the valve to the left of the lower filter to shut off the water intake. Then touch the sensor area to relieve water pressure from inside the unit.

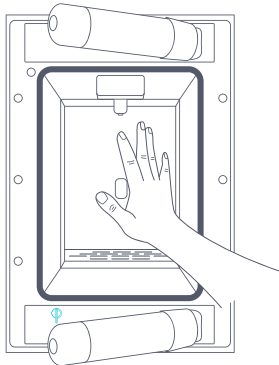

4. Slightly lift the lower sediment filter and twist it to remove it from its adapter inside the unit. Replace it by twisting the new sediment filter into this adapter.

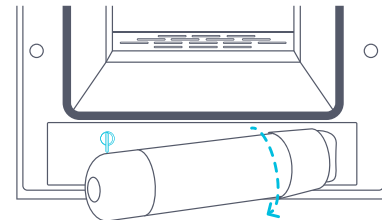

Filter Replacement

5. Slightly lift the upper carbon block filter and twist it to remove it from its adapter inside the unit. Replace it by twisting the new carbon block filter into this adapter.

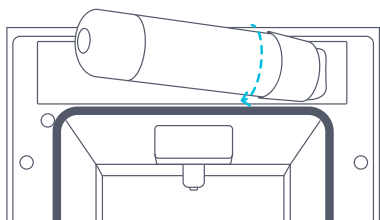

6. Hold down the filter reset button located behind the lower filter for 5 seconds to reset the filter life of the unit. The red Change Filter indicator will turn off and the green Filter Status indicator will light up to indicate that the filters have been reset.

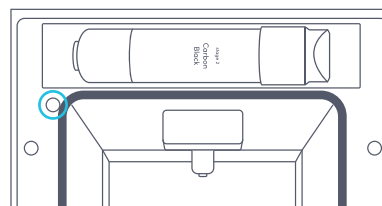

7. Turn on the valve to the left of the lower filter.

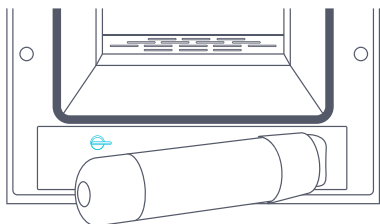

8. Replace the stainless steel faceplate back onto the front of the unit by lowering it onto the 2 notches at the top.

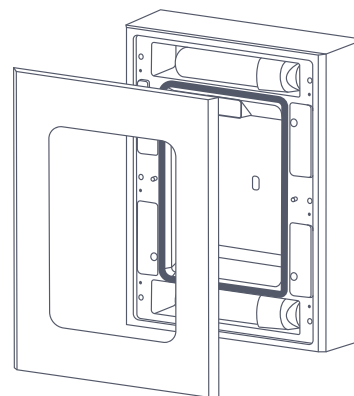

Filter Replacement

9. Screw on the 2 screws on the underside of the unit to secure the stainless steel faceplate.

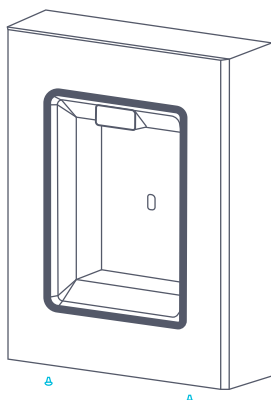

10. Touch sensing area with hand to fill water. Move away your hand after water flows out from the faucet. Inspect for leakage and then filter replacement is complete.

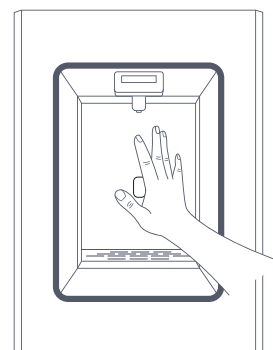

11. Flush the new filters by allowing water to dispense from the spout for approximately 1 minute. The bottle filler will stop dispensing water after 30 seconds for safety purposes so you may need to replace your hand in front of the sensor more than 1 time.

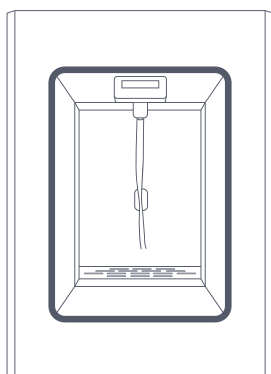

Connecting to the App

1. Scan the QR code to download the Avalon app compatible on android and Apple devices. You may also search for the Avalon app in Google Play or App Store.



2 Once the app is installed, you will need to create your Avalon account with your email.

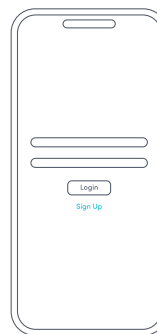

3. After creating your account, you can add your devices to your account. Hold down the filter reset button on the bottle filler to enter discovery mode. Click + Device from inside the app to add your bottle filler to your account.

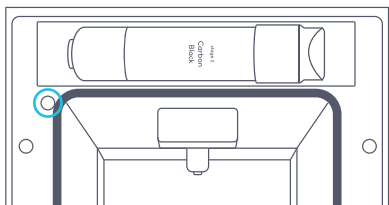

4. Once the bottle filler is added, you will be able to keep track of the unit directly from your phone or device.



Troubleshooting

Error Code	Trouble	Solution
E1	Lack of water/ no water from outlet	Check water supply, solenoid valve, flow meter
E2	Water leakage	Check flow meter or leaking fittings(cut off power and water supply before operating, after troubleshooting, pull out the water inlet pipe to relieve pressure, then turn water supply and power on again
E3	Filter expired (indicator turns red)	Long press reset button for 5S after changing filter
/	UV fault/UV expired (indicator blinking)	Check and change UV lamp
/	No cold water	Check cooling system
/	Water outlet sensor keeps dispensing	Check and change the solenoid valve
/	Small water flow form outlet	Check and change the rectifier
/	LED light is not on	Check circuit lines
/	Display screen doesn't show anything	Check power supply & the circuit
/	No sensing or insensitive	Adjust distance between hand and sensor

Warranty

Warranty

Models included are:

A1TLWATERCOOLER, A2TLWATERCOOLER, A3BLOZONETRCLR, A3F, A3F-SC, A4BLWTRCLR, A4F, A1BOTTLELESS, A5BOTTLELESS, A5BLK, A6BLWTRCLRWH, A6BLWTRCLRBLK, A7BOTTLELESS, A7BOTTLELESSBLK, A8CBOTTLELESSWHT, A8CBOTTLELESSBLK, A9CTELECTRICSS, A9ELECTRICBLK, A9ELECTRICWHT, A10-TL, A11-CTTL, A12-CTPOU, A13, A14, A15, A1CTWTRCLRBLK, A1CTWTRCLRWH, A3BLK, A4F, A5BLK, A6SC-WHT, A6SC-BLK, A10BLK, A11BLK, A12BLK, A13BLK, A14BLK, A13CT, A13-S, B8WHT, B8BLK, A9, A23, A23BLK, A24, A25, A25BLK

Products listed above are covered by the terms of this Limited Warranty. For purposes of this Limited Warranty, the term "product" means any water cooler bottled or bottleless manufactured for Avalon. Avalon warrants that it will, at Avalon's option, replace or repair the Purchaser's Avalon product sold in the U.S. or Canada by an authorized retailer if that product is defective due to faulty workmanship or materials, subject to the limitations described in this Limited Warranty. Avalon undertakes no responsibility for the quality of the goods except as otherwise provided in this warranty. There are no warranties that extend beyond the description on the face hereof. This Limited Warranty is valid only in connection with the original purchase of new products from authorized retailers and extends from the original purchase date of the original product purchased. This warranty extends only to the original purchaser of the product and lasts for one (1) year from the date of the original purchase or until the original purchaser of the product sells or transfers the product, whichever first occurs. An "original purchaser," for the purposes of this Limited Warranty, is an individual or entity who purchases the product directly from Avalon or an authorized retailer of Avalon with the intent to use the product for personal consumer use and commercial or industrial use and not with the intent to resell the product. An "authorized retailer," for purposes of this Limited Warranty, is an individual or entity authorized by Avalon to sell the product directly to original purchasers. An individual or entity that purchases the product from whatever source with the intent to resell the product is an unauthorized reseller ("unauthorized reseller"). For the purpose of this Limited Warranty a "Third Party" would be considered any plumber, maintenance company, or individual hired by the Purchaser.

This Limited Warranty does not apply to used, refurbished, renewed, floor model or "demo" products, or to products sold by unauthorized resellers, including without limitation, unauthorized resellers on third party websites, including, without limitation, Craigslist, eBay, Amazon, etc. Unauthorized resellers are not "original purchasers" for the purpose of this Limited Warranty. If the purchaser is not the original purchaser of this product, the purchaser takes the product "AS IS," "with all faults" and without warranty. Avalon reserves the right to require a valid serial number located on your product to submit a valid claim under this Limited Warranty. Products where the serial number has been removed or evidence showing the removal or attempted removal of the serial number label will not be eligible to make a claim under this Limited Warranty. IF THE PURCHASE OF THIS PRODUCT WAS NOT DIRECTLY FROM AVALON, PROOF OF PURCHASE WILL BE REQUIRED TO DEMONSTRATE THAT PURCHASER IS THE ORIGINAL PURCHASER AND THE PRODUCT WAS PURCHASED FROM AN AUTHORIZED RETAILER, AND ELIGIBLE TO MAKE A VALID CLAIM UNDER THIS LIMITED WARRANTY.

Your purchase date is established from the date of your sales receipt. Avalon may require the purchaser to provide proof of the quality and condition of the water cooler if the purchaser makes a claim under this Limited Warranty. Avalon reserves the right to invalidate this Limited Warranty if the water cooler is determined, in Avalon's reasonable discretion, to be inadequate or if the water cooler is found to be in an unsanitary condition. This warranty does not apply if the product was damaged or failed because of accident, improper handling or operation, relocation, abuse, misuse, unauthorized repairs made or attempted, or improper installation or maintenance. Under this Limited Warranty, products are required to be plugged directly into a grounded wall outlet. Plugging a product into an extension cord or surge protector will be considered misuse and will void this Limited Warranty. If damage to the product has occurred during shipping, the damage must be reported to Avalon within the first 30 days from the original purchase date to be eligible to make a claim under the Limited Warranty. Shipping damage reported to Avalon outside of the first 30 days from the original purchase date will not be eligible for a valid claim under this Limited Warranty. This warranty does not cover shipping costs for the return of products to Avalon for repair or replacement.

To submit a valid claim under this Limited Warranty, troubleshooting the product with an Avalon Customer Success Expert is required. If troubleshooting the product is refused by the Purchaser, Avalon reserves the right to deny the Limited Warranty Claim. In the event a part is necessary to correct the problem with a Product, Avalon will provide the part at no cost to the original purchaser under this Limited Warranty. Replacing parts or attempting to correct an issue with the Product is required prior to submitting a claim for a replacement product under this Limited Warranty. Instructions for troubleshooting a Product or replacing a part will be provided by Avalon. Troubleshooting, repairs, part replacement, installation, and proper maintenance are the responsibility of the Purchaser. Instructions for proper installation and maintenance will be provided in the user manual.

Installation, maintenance, or repairs of the Product is the responsibility of the Purchaser. The Purchaser reserves the right to use a Third Party for installation, maintenance, and repair at their own risk. Avalon is not responsible for any additional cost incurred for installation, maintenance, or repair of the Product including but not limited to additional material needed for installation or the cost of a Third Party. Damage or failure of the Product due to improper installation, maintenance, or repair caused by a Third Party or the Purchaser is not the responsibility of Avalon and will not be covered under this Limited Warranty. Instructions for proper installation and maintenance will be provided in the user manual.

ANY AND ALL WARRANTIES, EXPRESSED OR IMPLIED (INCLUDING, WITHOUT LIMITATION, ANY IMPLIED WARRANTY OF MERCHANTABILITY), LAST ONE YEAR FROM THE DATE OF ORIGINAL PURCHASE OR UNTIL THE ORIGINAL PURCHASER OF THE PRODUCT SELLS OR TRANSFERS THE PRODUCT, WHICHEVER FIRST OCCURS. IN NO EVENT SHALL AVALON'S LIABILITY UNDER ANY EXPRESS OR IMPLIED WARRANTY INCLUDE (I) INCIDENTAL OR CONSEQUENTIAL DAMAGES FROM ANY CAUSE WHATSOEVER, INCLUDING BUT NOT LIMITED TO ELECTRICAL OR WATER DAMAGE, OR (II) REPLACEMENT OR REPAIR OF ANY HOUSE FUSES, CIRCUIT BREAKERS OR RECEPTACLES. NOTWITHSTANDING ANYTHING TO THE CONTRARY, IN NO EVENT SHALL AVALON'S LIABILITY UNDER ANY EXPRESS OR IMPLIED WARRANTY EXCEED THE PURCHASE PRICE OF THE PRODUCT AND ANY SUCH LIABILITY SHALL TERMINATE UPON THE EXPIRATION OF THE WARRANTY PERIOD.

Except as otherwise provided, Avalon will not charge Original Purchaser to repair or replace the purchaser's Product if it is deemed defective during the length of this Limited Warranty, but any transportation costs associated with repairs or replacements are Purchaser's responsibility. No new warranty is provided with a replacement product. The warranty for the replacement product runs from the date of the original purchase of the original product. In the event that repair is necessary, such repair will be at no charge to the Purchaser except for transportation costs associated with such repair or replacement of a product in compliance with the terms of this Limited Warranty.

In the event, a warranty claim is filed and a warranty replacement is deemed necessary, the purchaser will be required to surrender the original product to Avalon at the time of replacement.

Some states and provinces do not allow limitations on how long an implied warranty lasts or the exclusion or limitation of incidental or consequential damages, so these exclusions or limitations may not apply to you. This warranty gives you specific legal rights. You may also have other rights which vary from state to state and province to province.

